



User Manual

Mytee Hot Turbo

Models:
240-120, 480-120

REV. 1/26/22

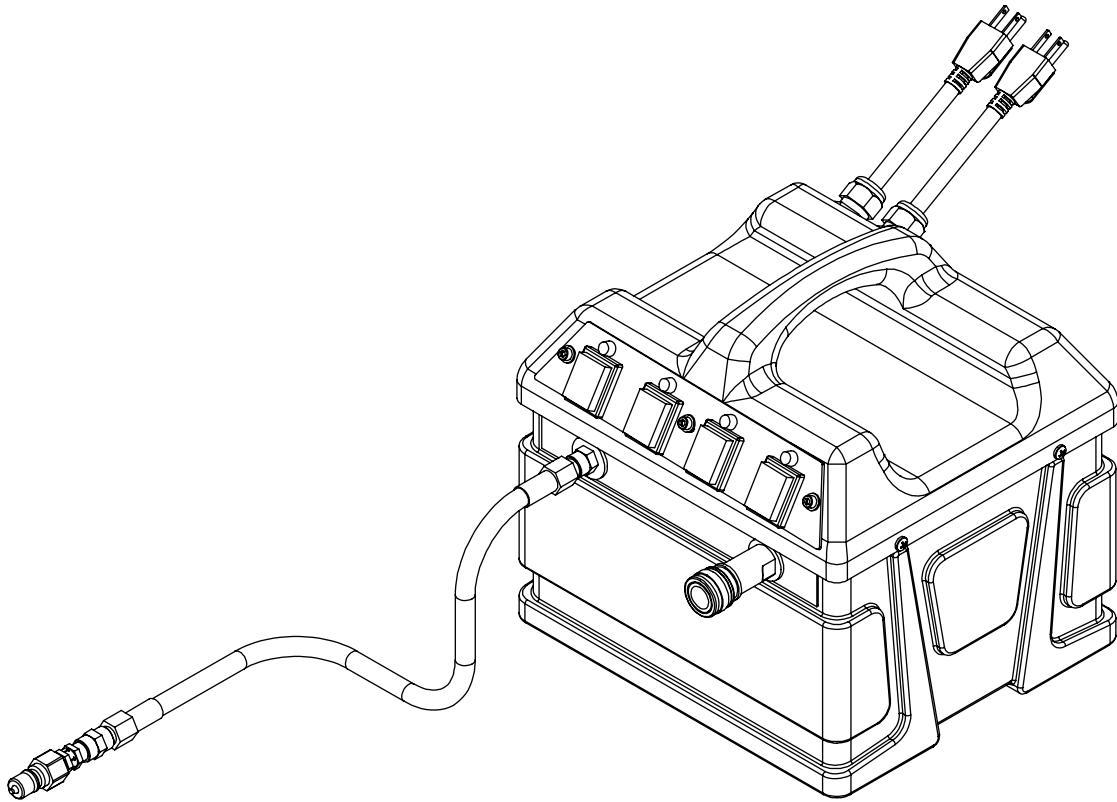

13655 Stowe Dr. Poway, CA 92064
P: (858) 679-1191
F: (858) 726-6005
www.mytee.com

Introduction

Dear Customer:

Congratulations on the purchase of your new Mytee Hot Turbo External Heater. As technology continues to develop you can work confidently knowing that both Mytee and its employees are equally dedicated to developing with the industry and its advances.

Like any other piece of machinery or technology, the Mytee Hot Turbo also requires proper maintenance and care to keep the product working over extended use. Neglecting your machine, abusing it or not operating it properly can void its warranty and prevent the machine from performing to the quality and standard you'd expect out of the Mytee line.

If you have any warranty concerns or questions, please review this manual thoroughly or do not hesitate to contact your distributor. If there are questions regarding maintenance, replacement, or ordering parts please contact an authorized Mytee Service Center. To see an updated list please visit our website at <http://www.mytee.com/support/service-centers>.

Before using your Mytee product, please read this manual thoroughly.

Sincerely,
Mytee Customer Care Dept.

| | | |
|----------|---|----------|
| | Important Safety Information | 4 |
| 1 | At a Glance | 6 |
| | 1.1 - Technical Specifications | 6 |
| | 1.2 - Product Features | 6 |
| 2 | Machine Operation | 7 |
| | 2.1 - Powering the Mytee Hot Turbo | 7 |
| | 2.2 - Connecting to Extractor/Truckmount | 7 |
| | 2.3 - Operation | 7 |
| 3 | Machine Maintenance | 8 |
| | 3.1 - Opening the Machine for Maintenance | 8 |
| | 3.2 - System Maintainer | 8 |

Important Safety Information

Please read and understand this manual completely before operating this machine.

Grounding Instructions

This machine must be grounded. If it should malfunction or break down, grounding provides a path of least resistance for electrical shock. This machine is equipped with a cord having an equipment-grounding conductor and grounding plug. The plug must be plugged into an appropriate outlet that is properly installed in accordance with all local code and ordinances. Do not remove ground pin; if missing, replace plug before use.



DANGER

Improper installation of the equipment-grounding conductor can result in a risk of electric shock. Be sure to check with a qualified electrician or service person if you are in doubt as to whether the outlet is properly grounded. If the plug will not fit in the outlet do not modify the plug or the machine's cord, instead have a proper outlet installed by a qualified technician.

This machine is for use on a nominal 120-volt circuit and with a grounding plug similar to the one in Figure 1 below. If a proper outlet is not available, follow the illustrations of Figure 2 & 3 to install a temporary-grounding plug. This temporary work-around should be used only until a proper outlet (Figure 1) can be installed by a qualified electrician. When and if this type of adapter is employed, screw the adapter's extended tab into place with a metal screw. However, grounding adapters are not approved for use in Canada.

Again, be sure to check the grounding pin for damages and replace if necessary.

The Green, or Green-Yellow, wire in the cord is the grounding wire. When replacing a plug, this wire must be attached to only the grounding pin.

DO NOT use extension cords.

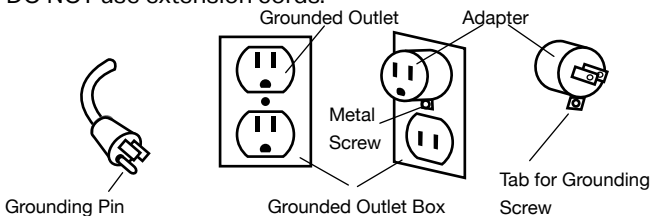

Figure 1

Figure 2

Figure 3

Please Note for America use only.

Parts and Service

Please contact Mytee service personnel or a Mytee authorized Service Center using Mytee original replacement parts and accessories if repairs need to be performed. When and if calling Mytee for support, please have your Model and Serial Number available for faster assistance.

Name Plate

The Model and Serial Number are located on the lower half of the back of the machine near the power plug and will be required for ordering replacement parts. You can use the space provided in this manual to note down both for future referencing.

Unpacking the Machine

When your new machine is delivered, please carefully inspect both the shipping carton and the machine for damages. If damage is evident, save both the shipping carton and machine so that the delivering carrier can inspect it. Contact the carrier immediately to file a freight claim if there has been any damage.

Caution and Warnings

Symbols

Mytee uses the symbols below to signal potentially dangerous conditions. Always read this information carefully and take the necessary steps to protect personnel and property.



DANGER

Is used to warn of immediate hazards that will cause severe personal injury or death.



WARNING

Is used to call attention to a situation that could cause severe personal injury.



CAUTION

Is used to call attention to a situation that could cause minor personal injury or damage to the machine or other property. When using an electrical appliance, basic precautions should always be followed, including the following: Read all instructions before using this machine. This product is intended for commercial use only.

Important Safety Information

To reduce the risk of fire, electrical shock, or injury:

- 1.** Read all instructions before using equipment.
- 2.** Use only as described in this manual. Use only manufacturer's recommended attachments.
- 3.** Always unplug power cord from electrical outlet before attempting any adjustments or repairs.
- 4.** Do not unplug by pulling on cord. To unplug, grasp the plug, not the cord.
- 5.** Do not pull or carry by cord. Do not close a door on cord or pull cord around sharp edges or corners.
- 6.** Do not run appliance over cord. Keep cord away from heated surfaces.
- 7.** Do not use with damaged cord or plug. If cord is damaged, repair immediately.
- 8.** Do not use outdoors or on wet surfaces and/or standing water.
- 9.** Always unplug or disconnect the appliance from power supply when not in use.
- 10.** Do not allow to be used as a toy. Close attention is necessary when used by or near children.
- 11.** Do not use in areas where flammable or combustible material may be present.
- 12.** Do not leave the unit exposed to harsh weather elements. Temperatures below freezing may damage components and void warranty.
- 13.** Use only the appropriate handles to move and lift unit. Do not use any other parts of this machine for this purpose.
- 14.** Keep hair, loose clothing, fingers, and all parts of the body away from all openings and moving parts.
- 15.** Use extra care when using on stairs.
- 16.** To reduce the risk of fire or electric shock, do not use this machine with a solid-state speed control device.
- 17.** The voltage and frequency indicated on the name plate must correspond to the wall receptacle supply voltage.
- 18.** When cleaning and servicing the machine, local or national regulations may apply to the safe disposal of liquids which may contain: chemicals, grease, oil, acid, alkalines, or other dangerous liquids.
- 19.** Do not leave operating unattended.

1 - At a Glance

1.1 - Technical Specifications

240-120 Mytee Hot Turbo

| | |
|---------------------------|--|
| Max. Pressure | 1,500 PSI |
| Max. Temperature | 210° F |
| Max. Wattage | 2,400 W (4x 600 W) |
| Power Cord | Single 25' 12/3 |
| Amp Draw | 5 amps per switch @ 115V 2.5 amps per switch @ 230V |
| Product Weight | 26 lbs. |
| Product Dimensions | 11.5" x 12.5" x 11" |

480-120 Mytee Hot Twin Turbo

| | |
|---------------------------|---|
| Max. Pressure | 1,500 PSI |
| Max. Temperature | 210° F |
| Max. Wattage | 4,800 W (4x 1,200 W) |
| Power Cord | Dual 25' 12/3 |
| Amp Draw | 10 amps per switch @ 115V 5 amps per switch @ 230V |
| Product Weight | 30 lbs. |
| Product Dimensions | 11.5" x 12.5" x 11" |

1.2 - Product Features

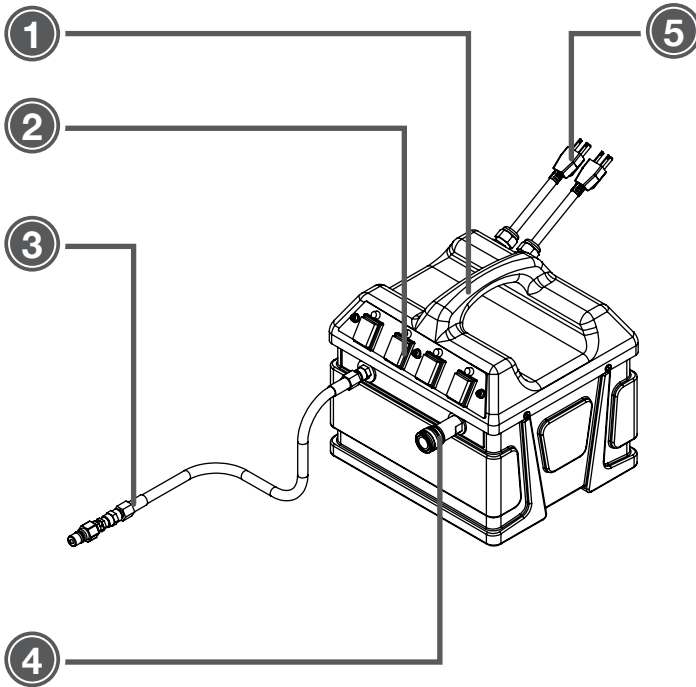

1. Carrying Handle
2. Switch Plate
3. Input Hose with Male Quick Connect
4. Output Female Quick Connect Fitting
5. Power Cord(s)

2 - Machine Operation

2.1 - Powering the Mytee Hot Turbo

Plug the power cord(s) into the appropriate outlet(s).

For dual cord units, plug the two cords into two separate circuits. The indicator light will turn on when this is done. ♦

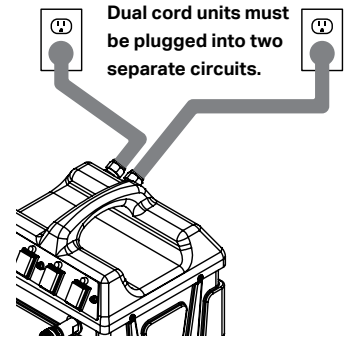

2.2 - Connecting to Extractor/Truckmount

Connect the input hose to your extractor or truckmount. A longer solution hose can be used between the Mytee Hot Turbo and the extractor if necessary.

Connect a solution line from the output connection to your cleaning tool. ♦

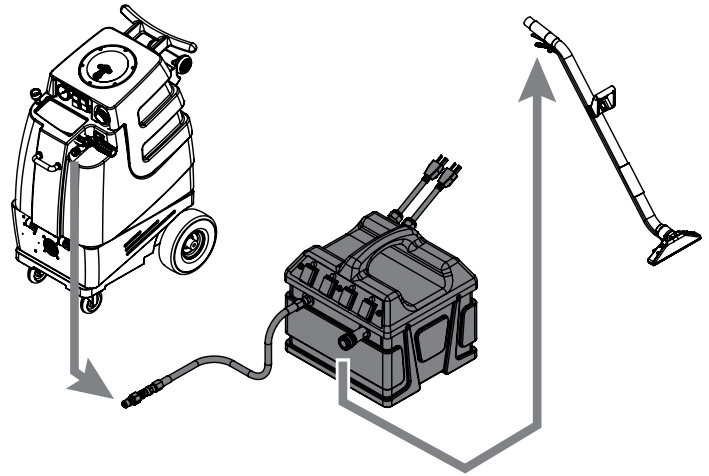

2.3 - Operation

In order to avoid vapor lock, the extractor/truckmount and Mytee Hot Turbo should be switched on by following the procedure below after a cleaning tool is connected:

1. Activate the pump on your extractor or truckmount. Pull the lever on the cleaning tool to release air in the line. Hold lever until a steady flow of water comes out of the tool.
2. Once pump is primed and there is pressure in the solution line, turn on however many heaters on the Mytee Hot Turbo you are using and wait a few minutes for water to heat up.
3. Once water is heated, turn on vacuum and begin cleaning. ♦

3 - Machine Maintenance

In order to keep the Mytee Hot Turbo operating smoothly and reduce the risk of damage to the machine and subsequent downtime, Mytee recommends following the maintenance schedule below:

| Maintenance Item | Daily | Weekly |
|--|-------|--------|
| Clean and inspect hoses and fittings. | X | |
| Check power cable. | X | |
| Clean machine with all-purpose cleaner and cloth. | X | |
| Flush solution system with Mytee System Maintainer | | X |

3.1 - Opening the Machine for Maintenance

Unscrew the four Phillips head screws around the outside of the heater lid. The lid can then be lifted off to gain access to the components. ♦

3.2 - System Maintainer

Regular flushing of the solution system with Mytee System Maintainer keeps your extractor running efficiently by removing hard water scaling that builds up in the system.

How to use System Maintainer:

1. Thoroughly mix System Maintainer with warm water at a 1:1 ratio in a separate container. Pour into your extractor's solution tank.
2. Connect the Mytee Hot Turbo to the extractor and connect a cleaning tool to the Mytee Hot Turbo.
3. Turn on the extractor's pump and run the System Maintainer solution through the Mytee Hot Turbo and into a bucket or receptacle until you have a solid stream.
4. Let sit for about 5 minutes while the System Maintainer solution works.
5. Finish running the rest of the solution through the system.
6. Run clean water through the system to flush out any remaining System Maintainer. ♦

NOTES



Mytee, LLC

13655 Stowe Dr.

Poway, CA 92064

www.mytee.com

© 2022 Mytee, LLC

Printed in the USA